

ITEM	PART NUMBER	DESCRIPTION	QTY	COMMENTS
1	MT3176 0000 13	TRAMMING LIGHT	1	
2	MT5112 3172 73	FUSE	4	40amp
3	MT5112 3172 736	FUSE		60amp
4	MT5112 3189 22F	FLANGE	1	
5	MT9111 4061 74	STRAINER	1	
6	MT1089 0376 46	TEMPERARURE GAUGE	1	
7	MT5112 3068 20	GAS SPRING	2	
8	MT3217 0010 73	CONTACT NO	1	
9	MT3217 0010 74	CONTACT NC	1	
10	MT3217 9060 16	CONNECTION PLATE	1	
11	MT3177 3085 00	GEAR PUMP	1	
12	MT9111 4068 51	CAT PUMP COUPLING COMPL.	1	
13	MT9111 4068 00	CAT 1010 PUMP	1	
14	MT5112 3083 78	COMPRESSOR BELT	1	
15	MT3222 3314 66	DYNASET WATER PUMP	1	
16	MT3222 3314 66B	DYNASET WATER PUMP	1	Bronze unit
17	MT9106 0713 06	BATTERY CHARGER	1	60amp
18	MT9106 0713 105	BATTERY CHARGER	1	105amp
19	MT5112 0012 12	RCS BATTERY	1	

PART NUMBER <b>MT0601</b>	DESCRIPTION <b>REAR FRAME</b>
	
Gavin Cunningham Ph. 0407 389 689 1 Haehy Circuit, Roseworthy S.A. 5371 <a href="mailto:parts@mtunderground.com">parts@mtunderground.com</a> <a href="mailto:gav@mtunderground.com">gav@mtunderground.com</a> <a href="mailto:admin@mtunderground.com">admin@mtunderground.com</a> <a href="http://www.mtunderground.com.au">www.mtunderground.com.au</a>	
	PAGE <b>6.1</b>

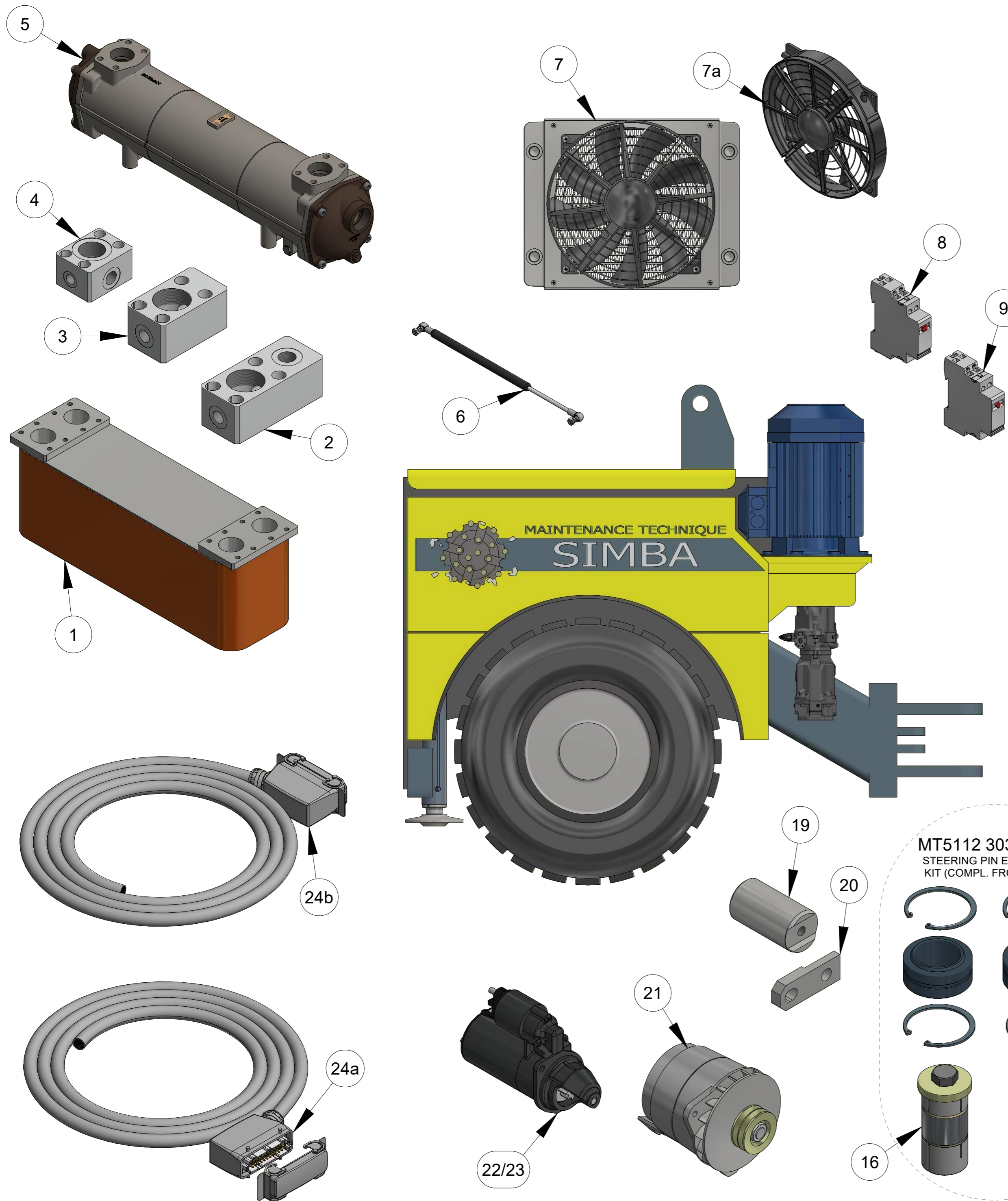

ITEM	PART NUMBER	DESCRIPTION	QTY	COMMENTS
1	MT9106 0774 91	OIL COOLER	1	
2	MT9110 8925 09	FLANGE CONNECT.	1	
3	MT9110 8924 86	FLANGE CONNECT.	1	
4	MT3214 3243 00S	MANIFOLD	1	
5	MT2403 8784 LD	HEAT EXCHANGER	1	
6	MT5112 3071 98	GAS SPRING	2	
7	MT3217 7511 60	AIR/OIL COOLER	1	
7a	MT3127 7511 81	AIR/OIL COOLER FAN	1	
8	MT3217 9583 01	RELAY	1	
9	MT3217 9299 05	REALY	1	Timer
10	MT5112 3043 10	LED FUSE HOLDER	6	ROI/D28
11	MT5112 3160 00	RESETTABLE FUSE	1	25amp
12	MT5112 3159 99	RESETTABLE FUSE	1	20amp
13	MT5112 3159 98	RESETTABLE FUSE	6	15map
14	MT5112 3159 9	RESETTABLE FUSE	6	10amp
15	MT5112 3037 00XB	EXPANDING SHAFT	1	Steering Cylinder
16	MT5112 3037 00XR	EXPANDING SHAFT	1	Steering Cylinder
17	MT0501 0019 01	BEARING	1	Steering Cylinder
18	MT0335 2165 00	CIRCLIP	1	Steering Cylinder
19	MT5112 3037 00	SHAFT	1	OEM
20	MT5112 3037 01	LOCK PLATE	1	OEM
21	MT5112 3217 90	ALTERNATOR	1	TCD2013
22	MT5112 3217 91	STARTER MOTOR	1	TCD2013
23	MT5112 3110 99	STARTER MOTOR	1	BF4M1013
24a	MT3176 0006 54	MAIN HARNESS	1	A51-A50
25b	MT3176 0006 44	MAIN HARNESS	1	A71-A50

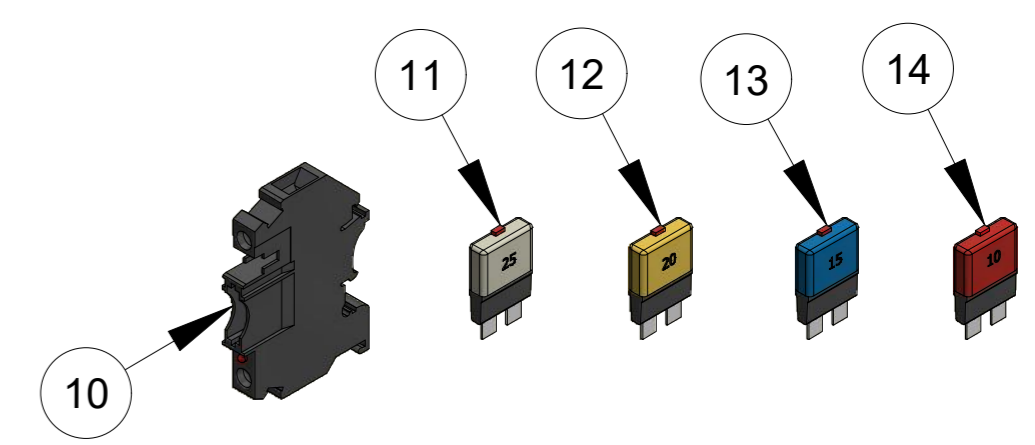
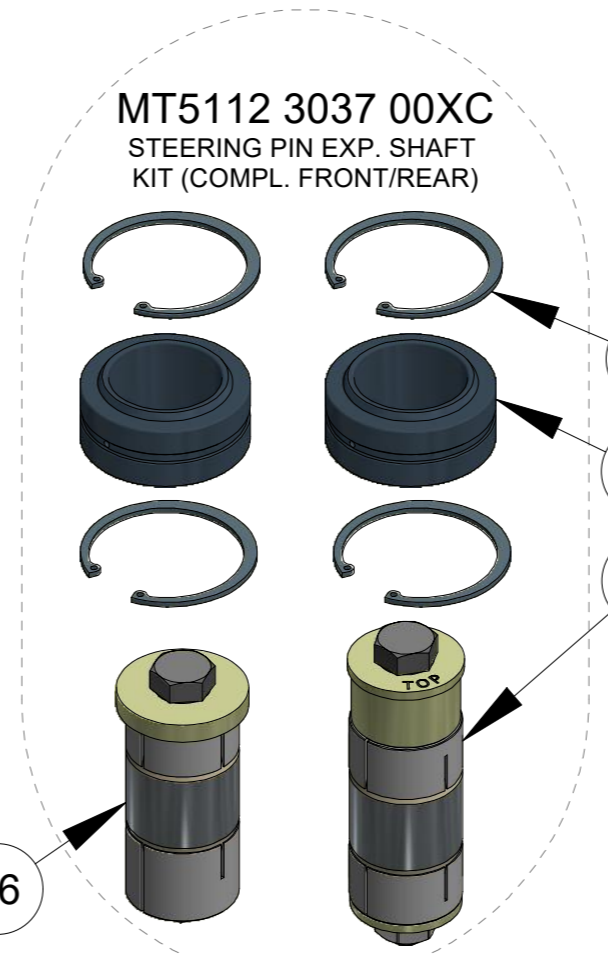

PART NUMBER: **MT0602** DESCRIPTION: **MOTOR FRAME**

Gavin Cunningham Ph. 0407 389 689  
 1 Haesy Circuit, Roseworthy S.A. 5371

[parts@mtunderground.com](mailto:parts@mtunderground.com)  
[gav@mtunderground.com](mailto:gav@mtunderground.com)  
[admin@mtunderground.com](mailto:admin@mtunderground.com)  
[www.mtunderground.com.au](http://www.mtunderground.com.au)

**MAINTENANCE TECHNIQUE**  
 UNDERGROUND DRILL RELIABILITY

PAGE: **6.2**

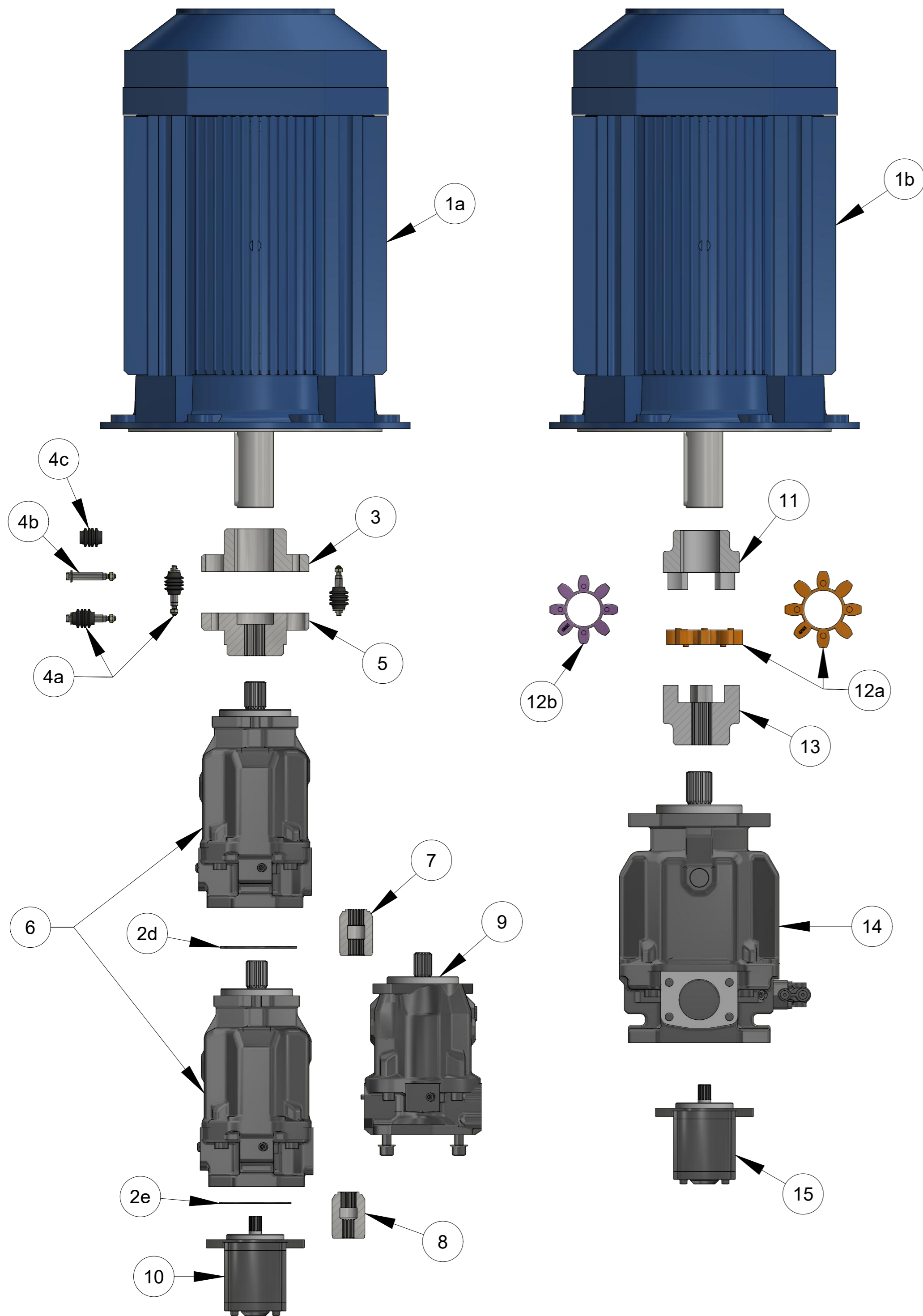

ITEM	PART NUMBER	DESCRIPTION	QTY	COMMENTS
1a	MT9106 1090 09SX	ELECTRIC MOTOR 75kw	2	SERVICE EXCHANGE ONLY
1b	MT9106 1089 14SX	ELECTRIC MOTOR 55kw		SERVICE EXCHANGE ONLY
2a	MT8231 0853 45	O-RING	1	
2b	MT8231 0853 46	O-RING	1	
2c	MT0663 2154 00	O-RING	1	
2d	MT3128 130N 70	O-RING	1	
2e	MT0663 2103 56	O-RING	1	
3	MT9111 3940 00T	COUPLING HALF	1	A10V 140 - MOTOR SIDE
4a	MT3715 0889 9K	SLEEVE	10	COMPLETE KIT
4b	MT3715 0889 90	BOLT SET	10	
4c	MT3715 0889 03	RUBBER SLEEVE	10	
5	MT9111 3940 00B	COUPLING HALF	1	A10V 140 - PUMP SIDE
6	MT3217 8762 00	PUMP	2	A10V 100
7	MT3217 8762 04	COUPLING	1	A10V 100 to A10V 100
8	MT3217 8762 03	COUPLING	1	GEAR PUMP to A10V 100
9	MT3217 8525 00	PUMP	1	A10V 71
10	MT3217 8822 37	COMPRESSOR PUMP	1	29cc, MOTOR SIDE A10V 100
11	MT3176 8502 90B	COUPLING HALF	1	PERCUSSION PUMP MOTOR
12a	MT9111 3940 11	GEAR RING	1	A10V 140
12b	MT9106 1275 98	GEAR RING	1	A10V 71, A10V 100
13	MT9110 3940 00T	COUPLING HALF	1	PERCUSSION PUMP SIDE
14	MT3217 8525 20	PUMP	1	A10V 140
15	MT9106 0111 00	GEAR PUMP	1	MT A/C UPGRADE PUMP KIT
16	MT3217 9203 02	COMPENSATOR	1	A10V 71, A10V 100, A10V 140
17	MT7606 5140	ADAPTOR	1	COMPENSATOR to 140CC PUMP
18	MT9106 1887 81	OIL LEVER SWITCH	1	

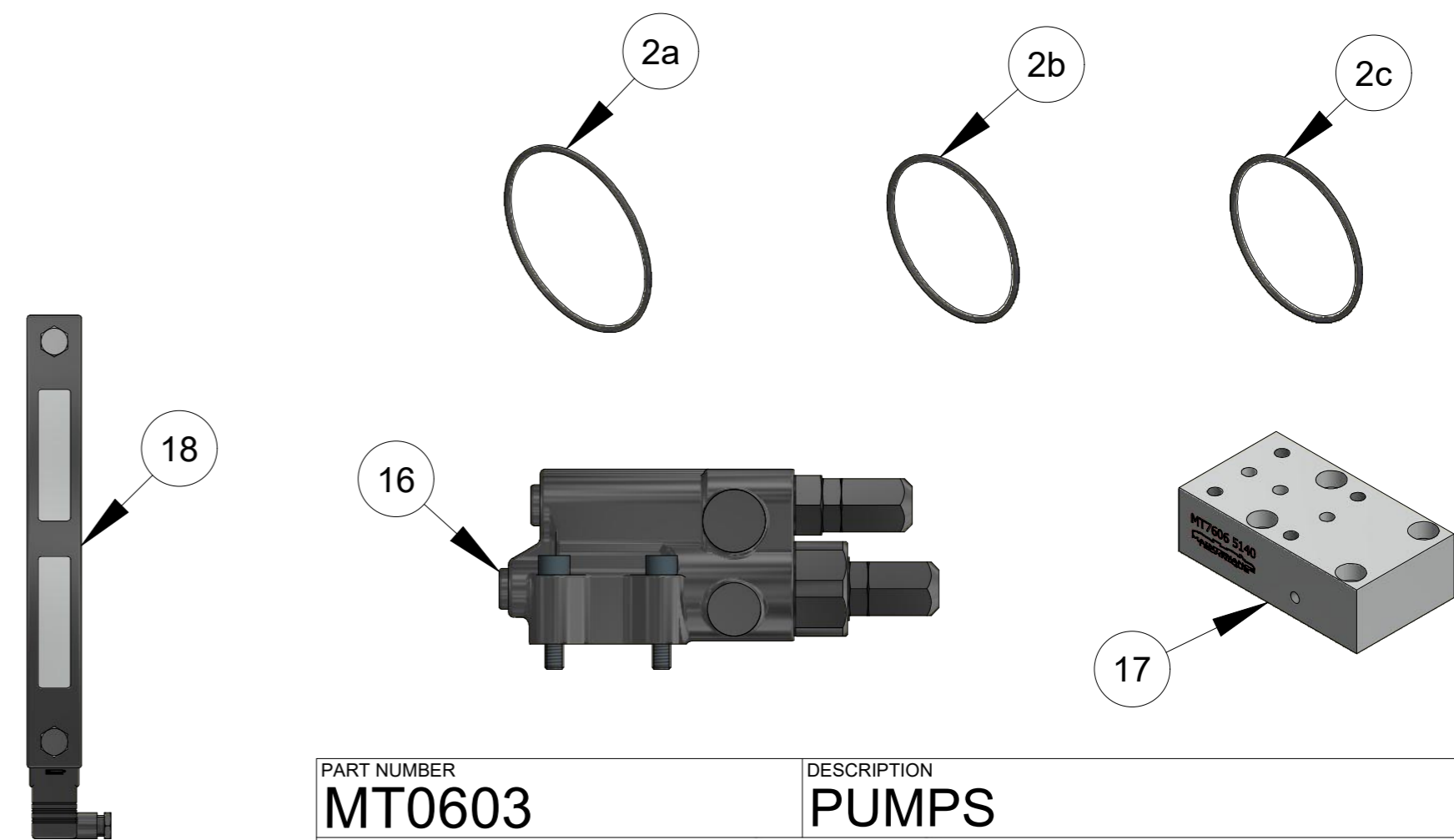

PART NUMBER: **MT0603** DESCRIPTION: **PUMPS**

**MAINTENANCE TECHNIQUE**  
UNDERGROUND DRILL RELIABILITY

Gavin Cunningham Ph. 0407 389 689  
1 Haesy Circuit, Roseworthy S.A. 5371

[parts@mtunderground.com](mailto:parts@mtunderground.com)  
[gav@mtunderground.com](mailto:gav@mtunderground.com)  
[admin@mtunderground.com](mailto:admin@mtunderground.com)  
[www.mtunderground.com.au](http://www.mtunderground.com.au)

PAGE 6.3

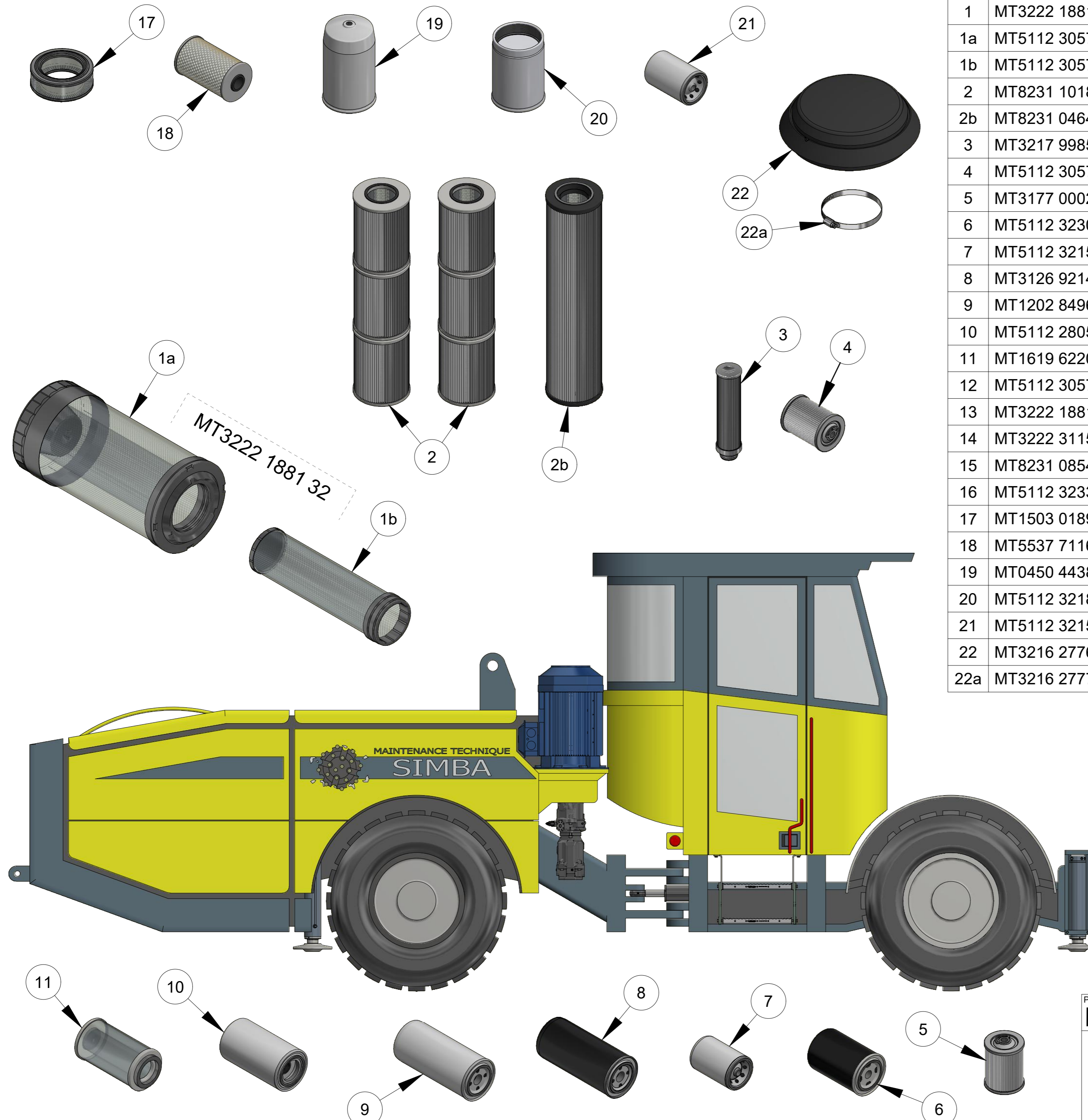

ITEM	PART NUMBER	DESCRIPTION	QTY	COMMENT
1	MT3222 1881 32	AIR FILTER SET	1	incl. 1a & 1b
1a	MT5112 3057 40	OUTER AIR FILTER ELEMENT	1	
1b	MT5112 3057 41	INNER AIR FILTER ELEMENT	1	
2	MT8231 1018 04	HYDRAULIC RETURN FILTERS	6	2 x 3 off
2b	MT8231 0464 10	HYDRAULIC RETURN FILTER	2	3 stack
3	MT3217 9985 101	ROTATION FILTERS	2	
4	MT5112 3057 74	SECONDARY FUEL FILTER	1	Deutz TCD 1013
5	MT3177 0002 29C	PRIMARY FUEL FILTER		Deutz TCD 2013
6	MT5112 3230 27	SECONDARY FUEL FILTER		Deutz TCD 2013
7	MT5112 3215 65	PRIMARY FUEL FILTER	1	Deutz TCD 1013
8	MT3126 9214 04	COMPRESSOR OIL FILTER	1	Gar 5
9	MT1202 8496 00	ENGINE OIL FILTER	1	
10	MT5112 2805 63	TRANSMISSION OIL FILTER	1	
11	MT1619 6220 00	COMPRESSOR AIR FILTER	1	Gar 5
12	MT5112 3057 250	250h SERVICE KIT DEUTZ BF4M1013C	1	incl. 1,4,7,8,9,10 & 11
13	MT3222 1881 250	250h SERVICE KIT DEUTZ TCD 2013	1	incl. 1,5,6,8,9,10 & 11
14	MT3222 3115 21	HAND PUMP	1	Mark 5 fuel primer
15	MT8231 0854 19	HYDRAULIC TANK BREATHER	1	
16	MT5112 3233 71	FUEL PRIMER COMPLETE	1	
17	MT1503 0189 00	AIR INTAKE FILTER	1	
18	MT5537 7116 00	E7 TRANSMISSION FILTER	1	
19	MT0450 4438	FUEL FILTER	1	
20	MT5112 3218 81	FUEL FILTER SPIN-ON	1	
21	MT5112 3215 35	FUEL FILTER PRIMARY	1	
22	MT3216 2776 00	AIR FILTER HOOD	1	
22a	MT3216 2777 00	AIR FILTER HOOD HOSE CLAMP	1	

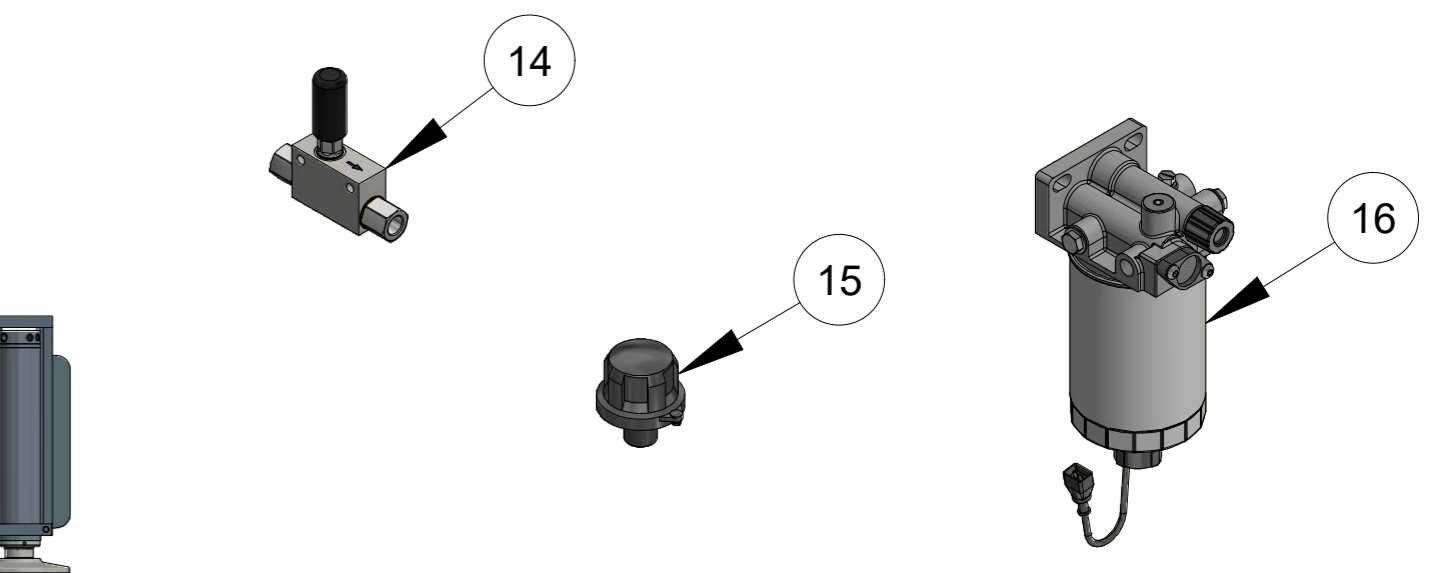

PART NUMBER <b>MT0604</b>	DESCRIPTION <b>FILTERS</b>
Gavin Cunningham Ph. 0407 389 689 1 Haesy Circuit, Roseworthy S.A. 5371 <a href="mailto:parts@mtunderground.com">parts@mtunderground.com</a> <a href="mailto:gav@mtunderground.com">gav@mtunderground.com</a> <a href="mailto:admin@mtunderground.com">admin@mtunderground.com</a> <a href="http://www.mtunderground.com.au">www.mtunderground.com.au</a>	
	PAGE <b>6.4</b>

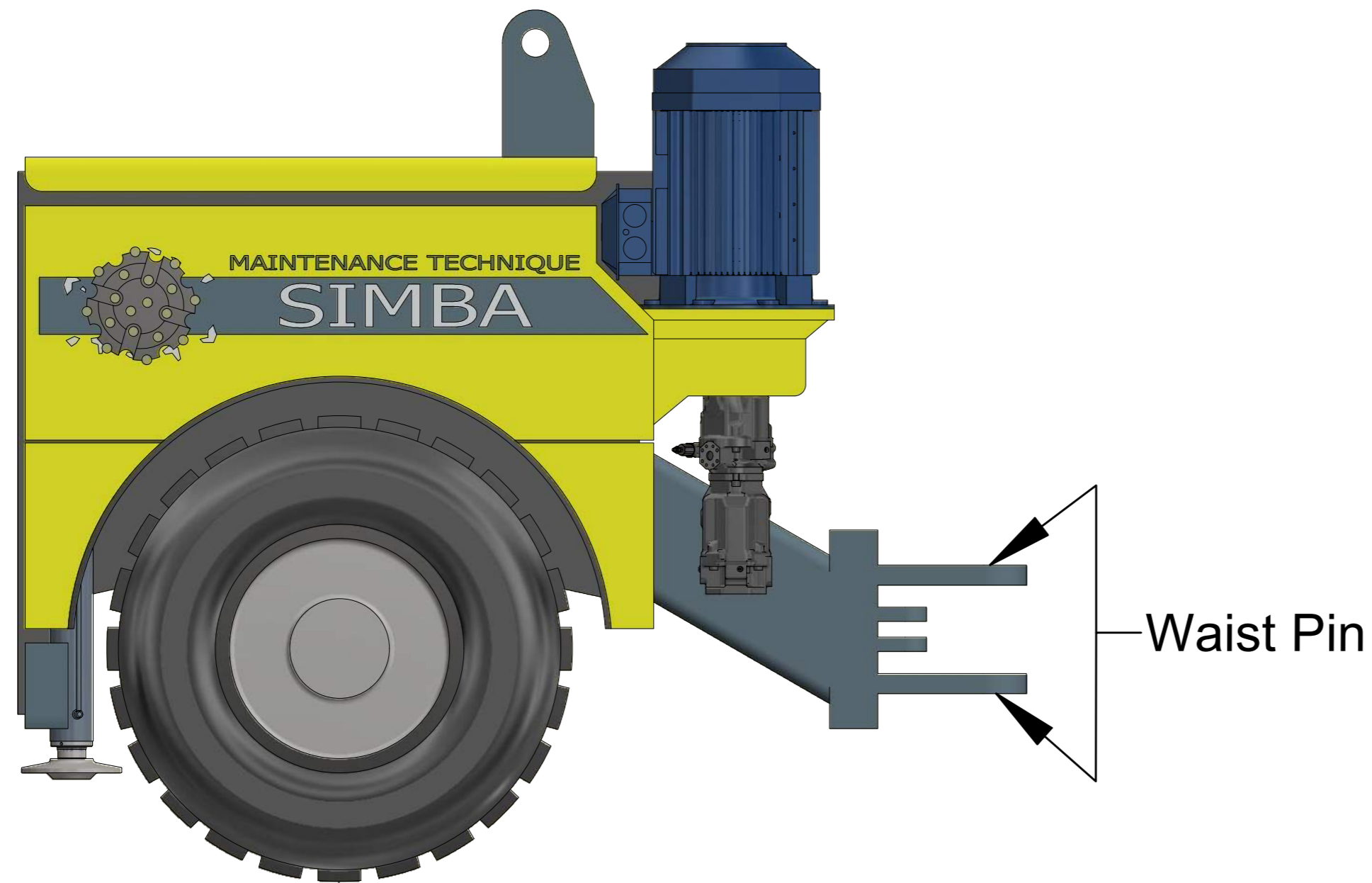

ITEM	PART NUMBER	DESCRIPTION	QTY	COMMENT
1	MT5112 3060 83XT	WAIST PIN EXP SHAFT TOP	1	80mm O.D.
2	MT5112 3060 83XB	WAIST PIN EXP SHAFT BOTTOM	1	80mm O.D.
3	MT5112 3062 08	PLAIN BEARING	1	
4	MT5112 3062 09	PLAIN BEARING	2	
5	MT5112 3062 0815	PLAIN BEARING O.D. +0.15mm	1	
6	MT5112 3062 0915	PLAIN BEARING O.D. +0.15mm	2	
7	MT5112 3060 83	WAIST PIN OEM	2	
8	MT0333 6117 00	LOCK WASHER	2	
9	MT0295 3117 00	LOCK NUT	2	
10	MT5112 3062 PK	PULLING TOOL KIT	1	To Suit 80mm Pin
11	MT5112 3305 50XT	WAIST PIN EXP SHAFT TOP	1	110mm O.D.
12	MT5112 3305 50XB	WAIST PIN EXP SHAFT BOTTOM	1	110mm O.D.
13	MT5112 3305 52	PLAIN BEARING	1	
14	MT5112 3305 51	PLAIN BEARING	2	
15	MT5112 3305 5215	PLAIN BEARING O.D. +0.15mm	1	
16	MT5112 3305 5115	PLAIN BEARING O.D. +0.15mm	2	
17	MT5112 3305 50	WAIST PIN OEM	2	
18	MT0333 6123 00	LOCK WASHER	2	
19	MT0295 3123 00	LOCK NUT	2	
20	MT5112 3305 PK	PULLING TOOL KIT	1	To Suit 110mm Pin

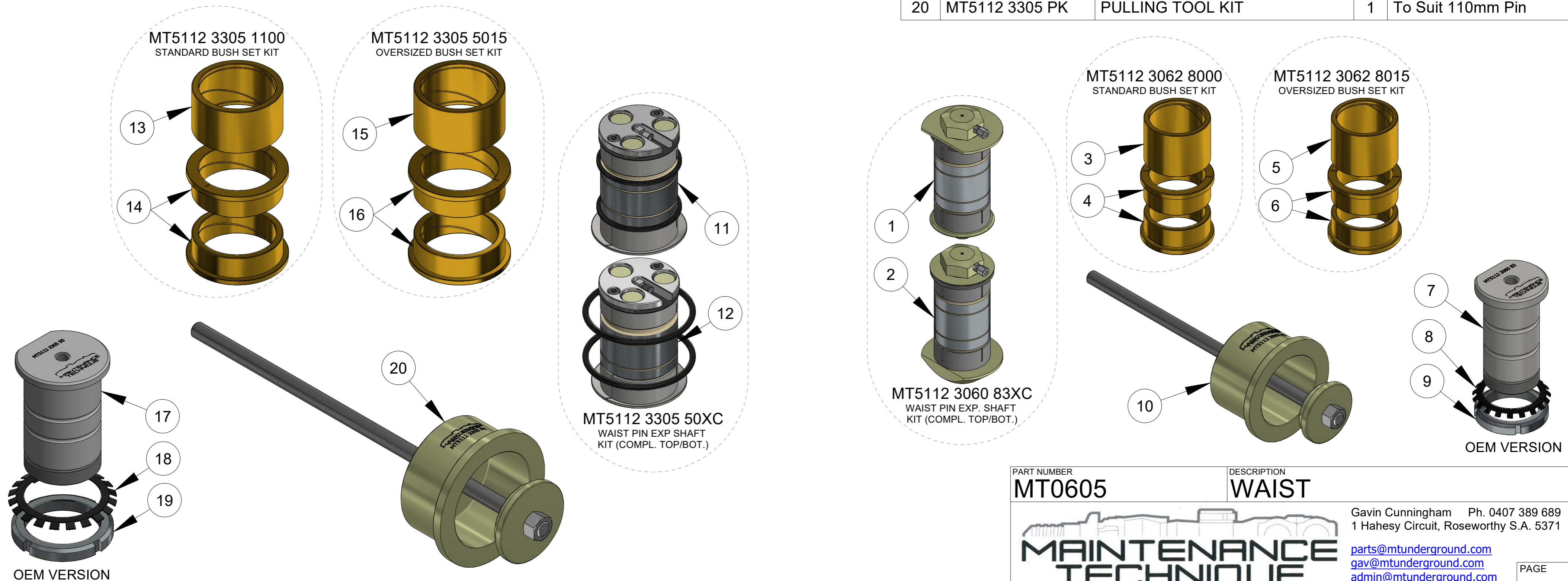

PART NUMBER <b>MT0605</b>	DESCRIPTION <b>WAIST</b>	Gavin Cunningham Ph. 0407 389 689 1 Haesy Circuit, Roseworthy S.A. 5371 <a href="mailto:parts@mtunderground.com">parts@mtunderground.com</a> <a href="mailto:gav@mtunderground.com">gav@mtunderground.com</a> <a href="mailto:admin@mtunderground.com">admin@mtunderground.com</a> <a href="http://www.mtunderground.com.au">www.mtunderground.com.au</a>
------------------------------	-----------------------------	--

**MAINTENANCE TECHNIQUE**  
UNDERGROUND DRILL RELIABILITY

PAGE  
**6.5**

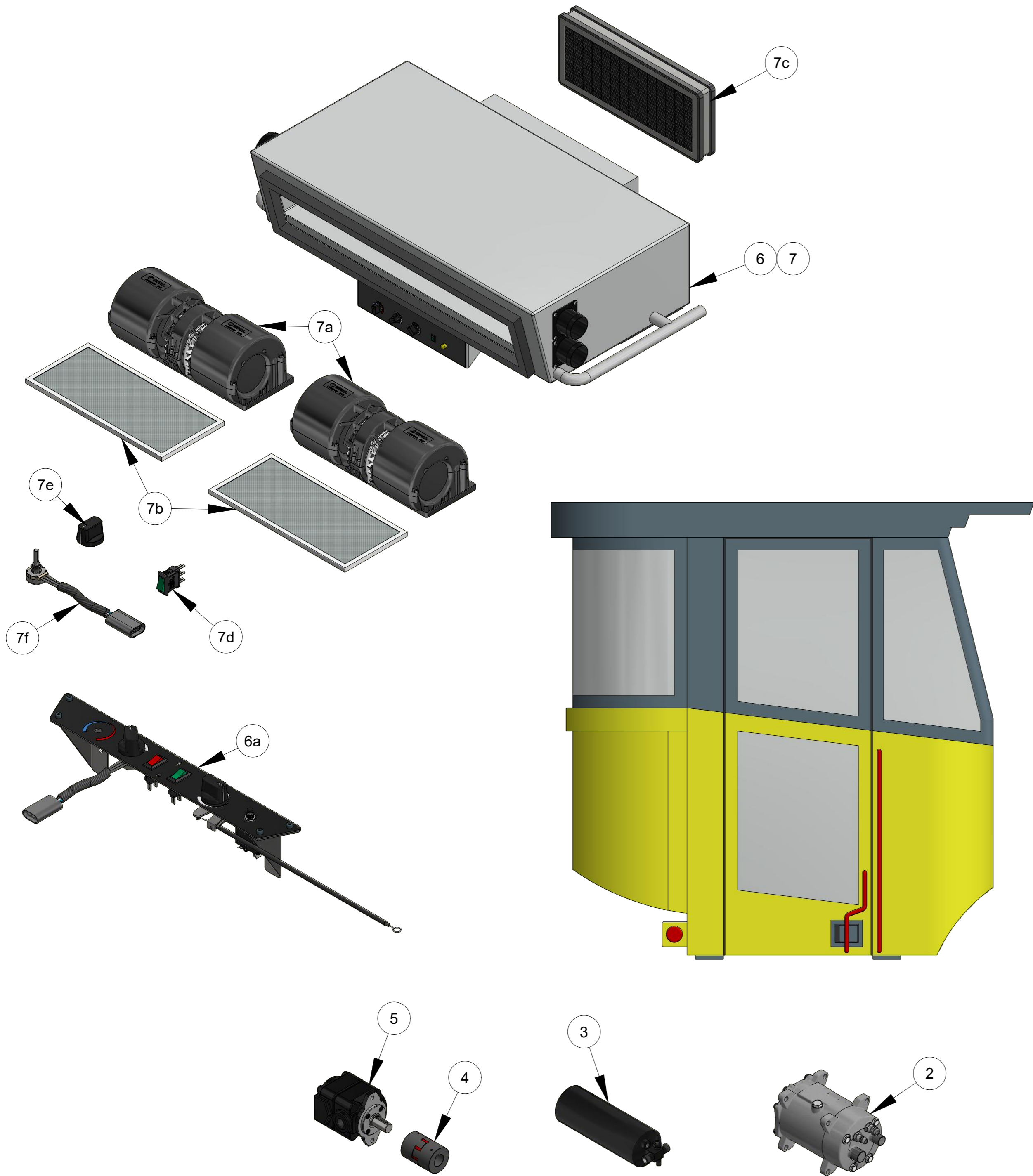

ITEM	PART NUMBER	DESCRIPTION	QTY	COMMENT
1	MT5112 3199 76	CONDENSER UNIT	1	
1a	MT5112 3085 86	CONDENSER FAN	2	
1b	MT5112 3199 77	CONDENSER	1	
2	MT9106 1887 08	AC COMPRESSOR	1	
3	MT3222 3104 47	RECEIVER DRYER	1	
4	MT9111 4068 51C	COUPLING & SPIDER	1	
5	MT3176 7889 14	DRIVE MOTOR	1	
6	MT9106 0080 61	AIR CONDITIONING UNIT	1	MARK 8 ONWRD
6a	MT9106 0080 61PA	A/C SWITCH PANEL	1	MARK 8 VARIANT
7	MT5112 3199 81	AIR CONDITIONING UNIT	1	
7a	MT3217 9778 39	EVAPORATOR FAN	2	
7b	MT5112 3300 41	FILTER	2	
7c	MT5112 3204 79	FILTER	1	
7d	MT5112 3085 82	CIRCUIT BREAKER	1	
7e	MT5112 3078 08	KNOB	1	
7f	MT5112 3078 87	POTENTIOMETER	1	

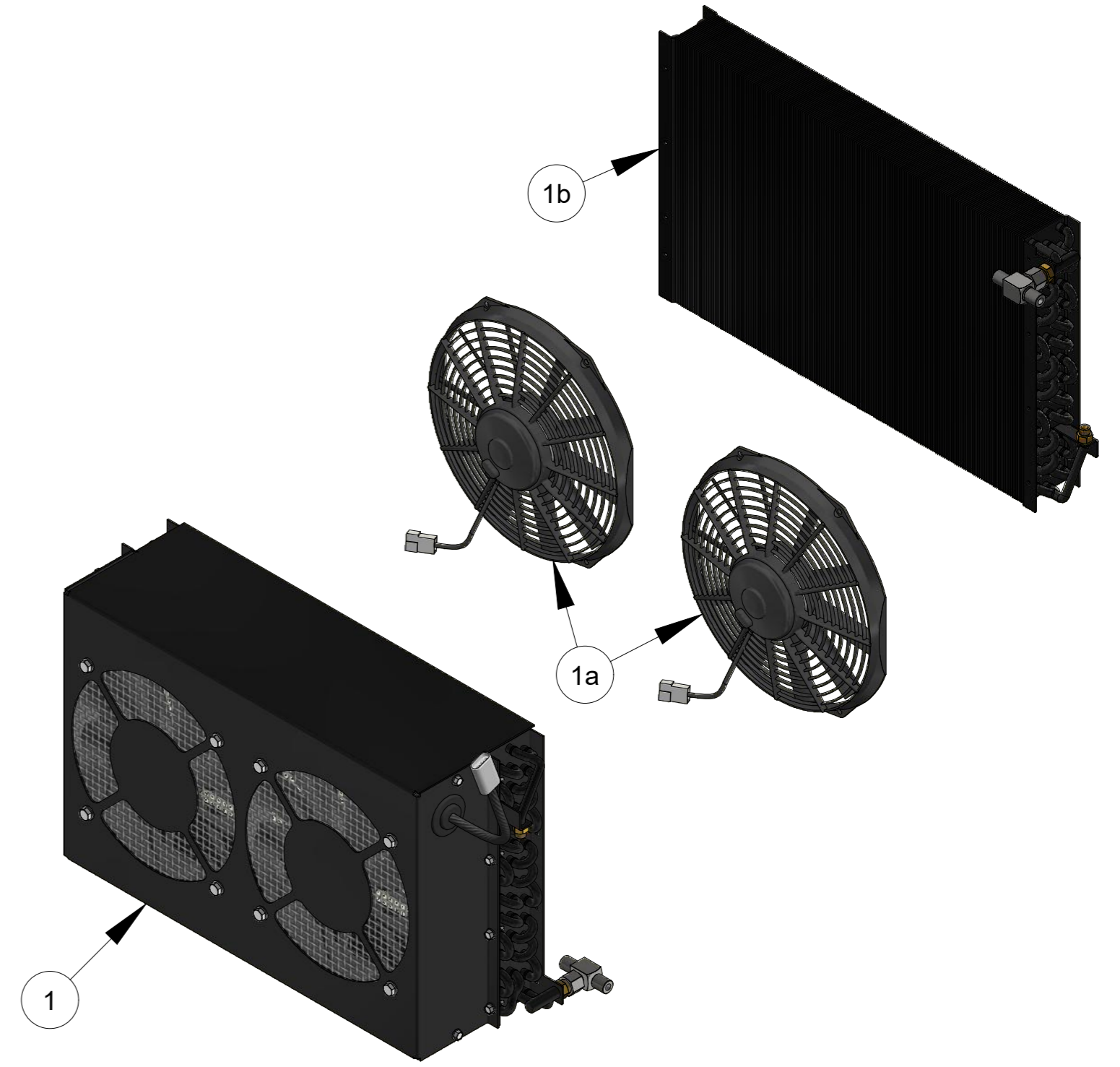

PART NUMBER <b>MT0606</b>	DESCRIPTION <b>CABIN AIR CONDITIONING</b>
	
Gavin Cunningham Ph. 0407 389 689 1 Haesy Circuit, Roseworthy S.A. 5371 <a href="mailto:parts@mtunderground.com">parts@mtunderground.com</a> <a href="mailto:gav@mtunderground.com">gav@mtunderground.com</a> <a href="mailto:admin@mtunderground.com">admin@mtunderground.com</a> <a href="http://www.mtunderground.com.au">www.mtunderground.com.au</a>	
PAGE <b>6.6</b>	

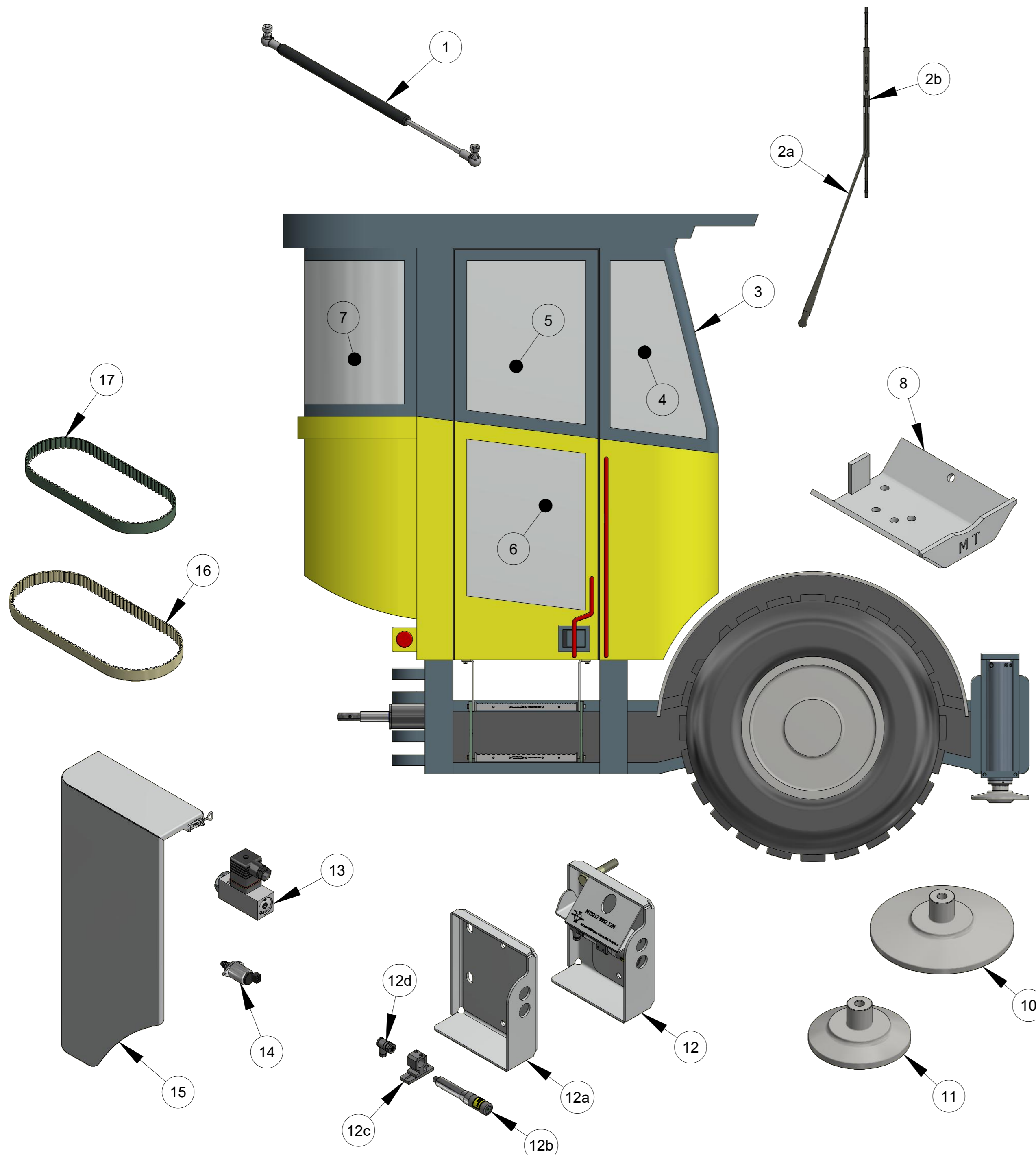

ITEM	PART NUMBER	DESCRIPTION	QTY	COMMENTS
1	MT5112 3068 20	GAS SPRING	1	Door Strut
2a	MT5112 3069 77	WIPER ARM	1	R/H Front Arm
2b	MT3217 9733 07	FRONT WIPER BLADE	1	
3	MT5112 3204 91	PANE		Front Window, 5 ply
4	MT5112 3200 36	RH CORNER PANE	1	
5	MT5112 3200 35	RH TOP DOOR PANE PANE	1	
6	MT5112 3200 23	RH BOTTOM DOOR PANE	1	
7	MT5112 3207 07	PLASTIC SHEET	1	Rear Window
8	MT3115 3032 80C	EXTRACT CRADLE	1	Mounts to Jack Leg
9	MT5112 3700 TB	FOOT REST TOOL BOX	1	Complete
10	MT9106 1702 35	JACK FOOT FRONT	1	
11	MT9110 8967 00	JACK FOOT REAR	1	
12	MT9106 2407 29R	COMPLETE LASER ATTACHM. RH	1	
12a	MT9106 2407 29	LASER ATTACHMENT	1	
12b	MT3217 9952 12	LASER	1	
12c	MT3217 9952 12B	BRACKET	1	
12d	MT3222 3190 PK	ANGULAR CONNECTOR	1	
13	MT9106 0882 327	PERCUSSION HOUR METER SW	1	
14	MT9106 1305 09	FEED ROTATION SOLENOID	1	
15	MT9111 4005 96R	VALVE ATTACHMENT DOOR RIGHT	1	
16	MT5112 0116 28	COG BELT	1	
17	MT5112 0116 850	COG BELT	1	

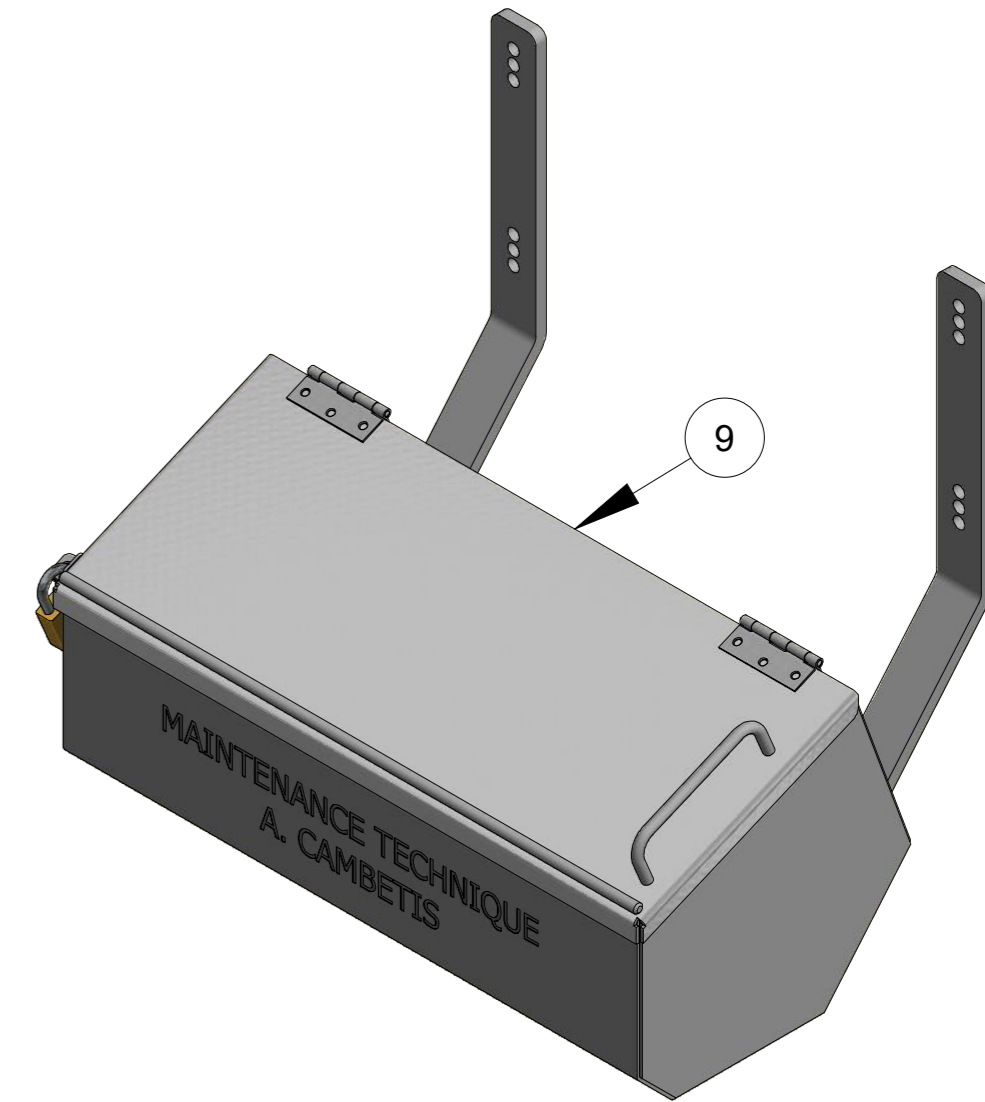

PART NUMBER  
**MT0607**

DESCRIPTION  
**FRONT FRAME RH**



Ph. 0407 389 689  
1 Haesy Circuit, Roseworthy S.A. 5371

[parts@mtunderground.com](mailto:parts@mtunderground.com)  
[gav@mtunderground.com](mailto:gav@mtunderground.com)  
[admin@mtunderground.com](mailto:admin@mtunderground.com)  
[www.mtunderground.com.au](http://www.mtunderground.com.au)

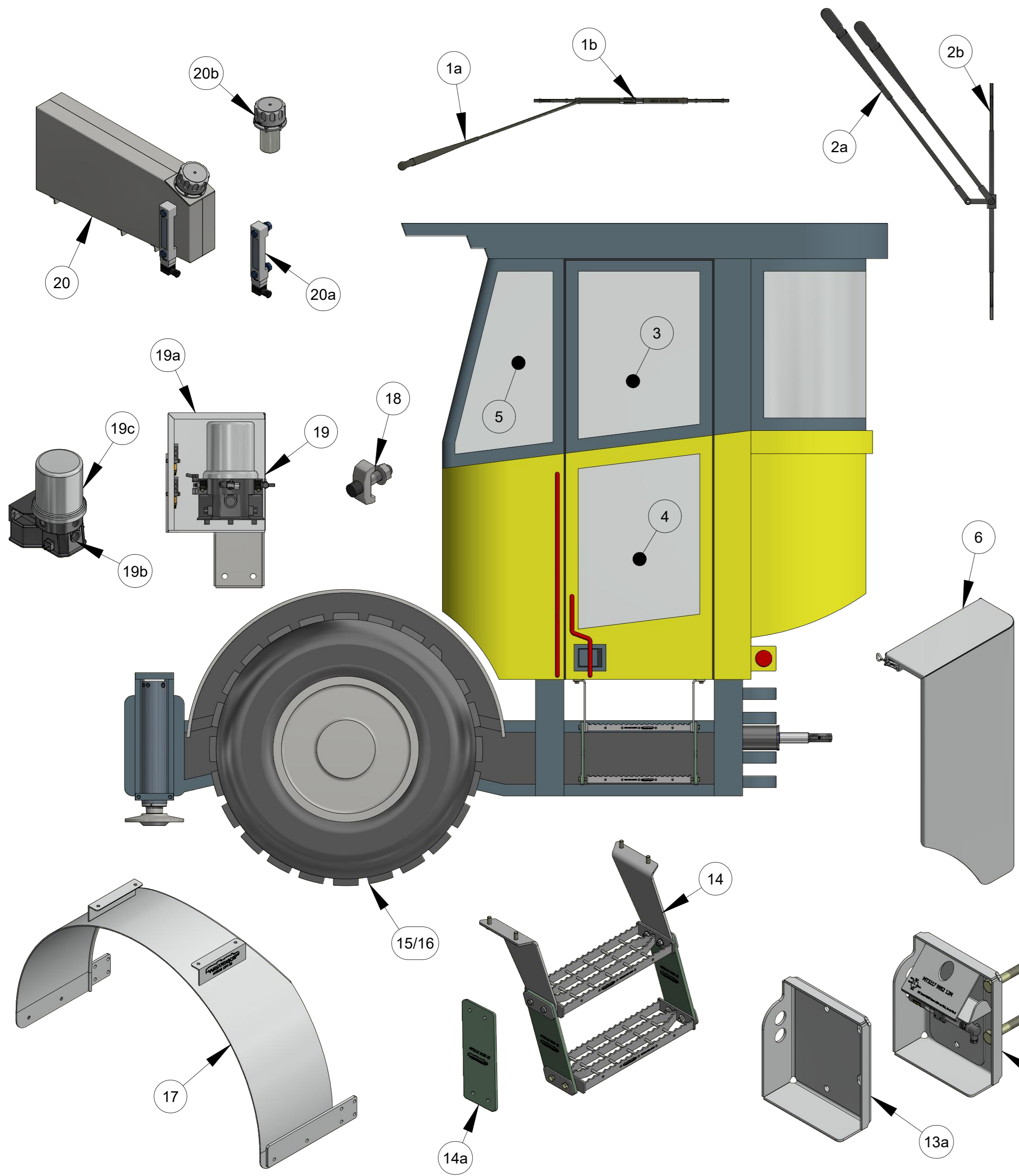

ITEM	PART NUMBER	DESCRIPTION	QTY	COMMENTS
1a	MT5112 3069 78	WIPER ARM	1	L/H Front Arm
1b	MT3217 9733 07	FRONT WIPER BLADE	1	
2a	MT3217 9732 10	REAR WIPER ARM	1	
2b	MT3217 9733 04	REAR WIPER BLADE	1	
3	MT5112 3200 70	LH TOP DOOR PANE	1	
4	MT5112 3200 69	LH BOTTOM DOOR PANE	1	
5	MT5112 3200 71	LH CORNER PANE	1	
6	MT9111 4005 96L	VALVE ATTACHMENT DOOR LEFT	1	
7	MT3217 9581 55	FLUSHING VALVE	1	
8	MT3217 9581 51	VALVE	1	
9	MT3217 9997 20PV	WATER MIST VALVE COMPLETE	1	incl. Coil
9a	MT3217 9997 21C	COIL	1	
10	MT3217 9581 70	VALVE SET	1	Air/Water Pilot Valve
11	MT3217 9955 40	FLOW GUARD - WATER	1	RCS3 and RCS4
12	MT9106 1856 03	AIR FLOW SWITCH	1	
13	MT9106 2407 40L	COMPLETE LASER ATTACHM. LH	1	see page 6.7 for more
13a	MT9106 2407 40	LASER ATTACHMENT	1	laser parts
14	MT5112 3130 01	STAGE COMPLETE	1	
14a	MT5112 3130 15	STAIRS SIDE	1	
15	MT5112 3056 SF	20" SOLID FRILL TYRE	1	
16	MT5112 3225 SF	24" SOLID FRILL TYRE	1	
17	MT9106 1274 60	MUDGUARD	1	Stainless Steel
18	MT5112 3039 64	DISPLAY MOUNT BOLTS	1	
19	MT3128 2538 36EC	AUTO GREASER COMPLETE	1	
19a	MT3128 2538 36E	GREASE PUMP HOUSING	1	
19b	MT3128 3049 45	GREASE PUMP CIRCUIT BOARD	1	
19c	MT3128 2538 36	GREASE PUMP	1	
20	MT3217 7403 00C	LUBE RESERVOIR COMPLETE	1	
20a	MT9106 2192 15F	LUBE RESERVOIR INDICATOR	1	
20b	MT3217 7403 FC	LUBE RESERVOIR CAP	1	

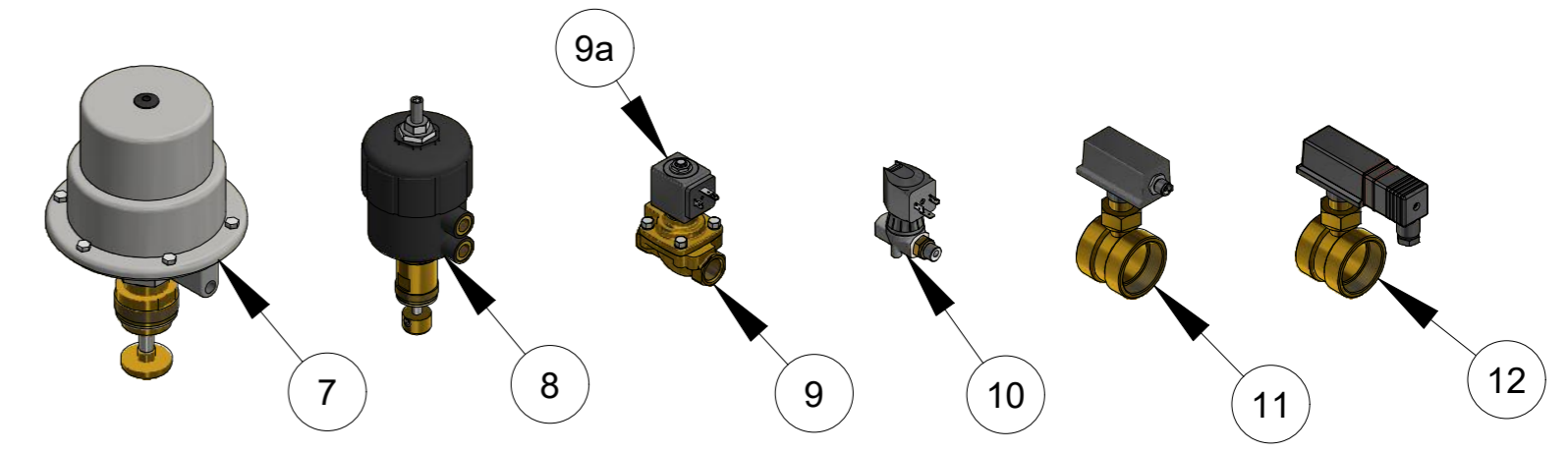

PART NUMBER **MT0608** DESCRIPTION **FRONT FRAME LH**

Gavin Cunningham Ph. 0407 389 689  
 1 Haesy Circuit, Roseworthy S.A. 5371

[parts@mtunderground.com](mailto:parts@mtunderground.com)  
[gav@mtunderground.com](mailto:gav@mtunderground.com)  
[admin@mtunderground.com](mailto:admin@mtunderground.com)  
[www.mtunderground.com.au](http://www.mtunderground.com.au)

**MAINTENANCE TECHNIQUE**  
 UNDERGROUND DRILL RELIABILITY

PAGE **6.8**



ITEM	PART NUMBER	DESCRIPTION	QTY	COMMENTS
1	MT5112 3079 38	SPOTLIGHT	1	
2	MT9106 2335 32F	AMBER FLASHING LIGHT	1	
3	MT5112 2918 10	DRILLING LIGHT	1	
4	MT9106 2335 32	AUTO LED LIGHT	1	
5	MT9106 1524 28	BARRIER SENSOR	1	RCS3
6	MT9106 2241 34	BARRIER SENSOR	1	RCS4
7	MT3128 3241 60	SENSOR ATTACHMENT BRACKET	1	
8	MT9106 1452 03R	CARD READER	1	
9	MT9106 1452 03	PCMCIA CARD	1	
10	MT9106 9702 55	USB MEMORY UNIT	1	
11	MT3176 0000 13	TRAMMING LIGHT	1	
12	MT9106 9733 94	RIG LEVEL SENSOR	1	RCS3
13	MT9106 2241 44	RIG LEVEL SENSOR	1	RCS4
14	MT5112 0039 16JM	JUNCTION BOX MOUNTING PLATE	1	
15	MT5112 0039 16JB	JUNCTION BOX	1	A51
16	MT3176 0015 39	EMERGENCY STOP	1	

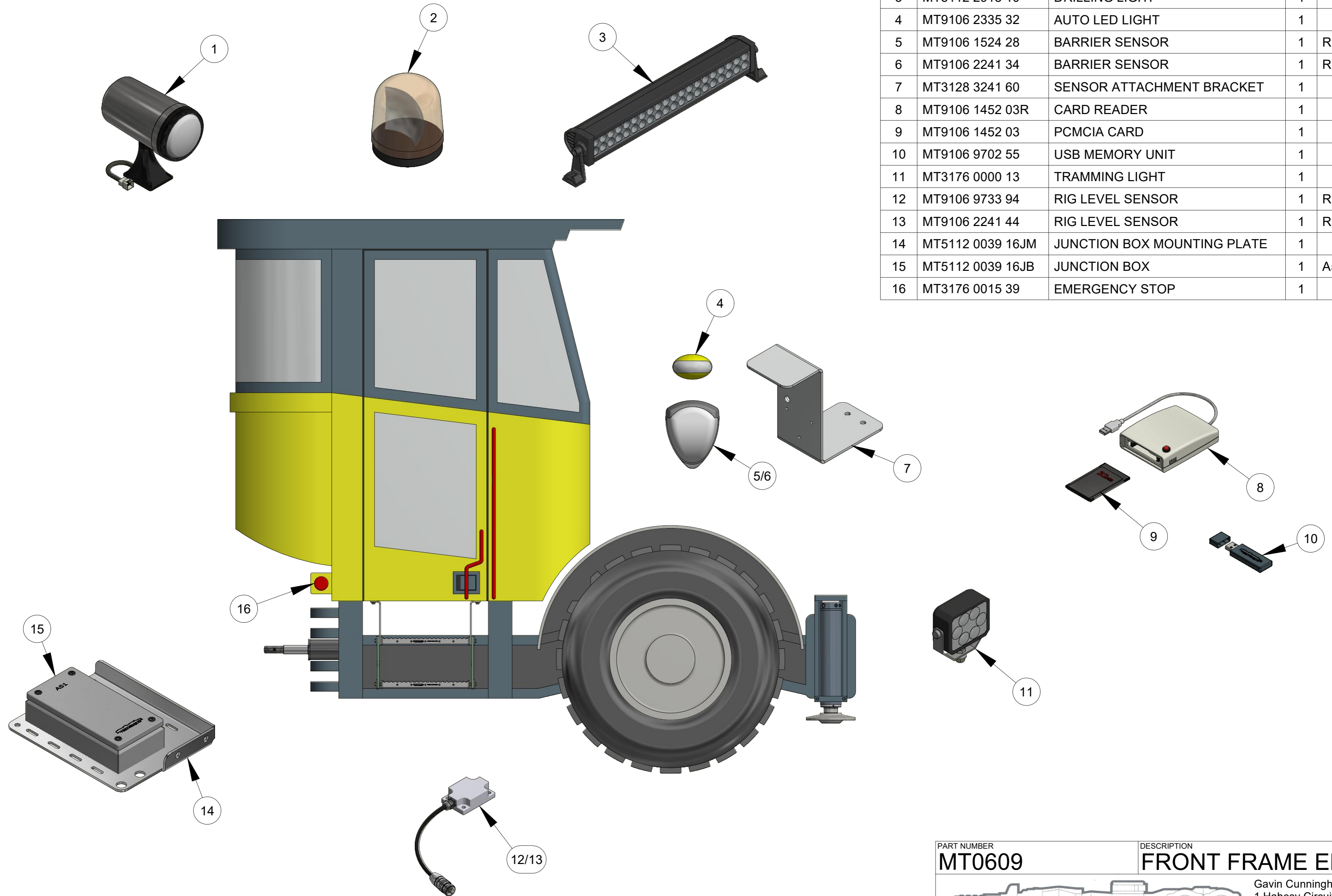

PART NUMBER	DESCRIPTION
MT0609	FRONT FRAME ELECTRICAL
Gavin Cunningham Ph. 0407 389 689 1 Haesy Circuit, Roseworthy S.A. 5371 <a href="mailto:parts@mtunderground.com">parts@mtunderground.com</a> <a href="mailto:gav@mtunderground.com">gav@mtunderground.com</a> <a href="mailto:admin@mtunderground.com">admin@mtunderground.com</a> <a href="http://www.mtunderground.com.au">www.mtunderground.com.au</a>	
PAGE	6.9